

# TITANTAG™ Secure HT

Frequency	UHF
Protocol	ISO18000-6-C EPC C1G2
Region	US
Dimensions (mm)	W95 H25 T2.5
Silicon chip	Alien Higgs3
Memory (bits)	TOTAL 800 EPC up to 480 User up to 512
Metal friendly	On metal
Reads up to meters	5.5 (On metal) n.a. (Off metal)
Operating temperature	-45<>85°C
Storage temperature	-45<>230°C
IP class	IP68
Year of release	2016
Product code	9525HTU

UHF C1G2 (US)	Silicon chips	W*H*T (mm)	Read (up to meters)	
			On metal	Off metal
Nail <sup>1/2</sup>	Alien Higgs3	13*7*2.1	0.2	0.2
Nail	Alien Higgs3	15*10*2.1	0.2	0.3
Inch TN	Alien Higgs3	26*10*2.1	0.7	0.5
Inch	Alien Higgs3	26*10*3.1	1.0	0.6
Inch SQ	Alien Higgs3	26*26*3.1	1.5	1.0
Inch SQ HT	Alien Higgs3	26*26*2.5	2.0	n/a
Tray NM	Impinj Monza4	35*15*3.1	n/a	1.0
Smallest	Alien Higgs3	38*10*3.1	2.5	1.0
Smallest AC	Alien Higgs3	38*10*3.1	2.5	0.5
Smallest MAG	Alien Higgs3	38*10*4.8	2.0	n/a
Tray U	Alien Higgs3	40*13*4.1	3.0	2.0
Smallest NM	Alien Higgs3	45*10*3.1	n/a	3.5
Spiral	Alien Higgs3	45*44*1.4	n/a	1.0
Strip	Alien Higgs3	60*6*3.1	2.0	0.5
Laundry	Alien Higgs3	68*9 *0.4	n/a	5.0
General TN	Alien Higgs3	75*16*2.1	2.5	2.0
General	Alien Higgs3	75*16*3.1	3.5	2.0
General AC	Alien Higgs3	75*16*3.1	3.5	2.0
Basic	Alien Higgs3	92*16*3.1	3.5	1.0
Basic MAG	Alien Higgs3	92*16*5.2	4.0	n/a
Basic L	Alien Higgs3	110*20*3.1	6.5	3.0
Pallet	Alien Higgs3	94*11*1.4	n/a	5.0
Secure	Alien Higgs3	95*25*3.1	5.5	8.0
Secure HT	Alien Higgs3	95*25*2.5	5.5	n/a
Blade	Alien Higgs3	139*6*4.0	6.5	5.5
Fastener	Alien Higgs3	148*18*3.1	7.0	9.0
Fastener MAG	Alien Higgs3	148*18*7.1	7.0	n/a
Fastener TK	Alien Higgs3	148*18*4.1	12.0	11.0
4KB5M	Fujitsu 803A	152*30*4.1	3.5	2.5

### [1] Secure HT Feature



### [2] Secure HT Dimensions (mm)

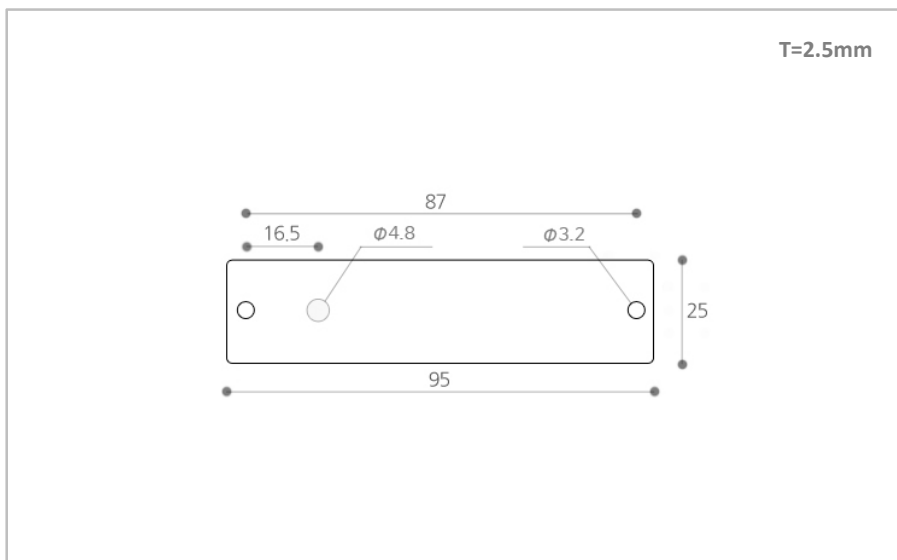

### [3] Secure HT Key materials and processes

#### Silicon chip Alien Higgs3

- Read sensitivity of -20dBm – Best performing among UHF Gen 2 RFID chips
- Total 800bits memory – EPC 96bits (extensible to 480bits), User 512bits, TID 64 bits, Access& Kill password each 32bits and Lock password 64bits
- Most widely adopted chip for metal mounting UHF RFID tags
- Rfcamp has adopted Alien Higgs3 since year of 2008.

[www.alientechnology.com/wp-content/uploads/ALC-360%20Higgs3%202014-12-21.pdf](http://www.alientechnology.com/wp-content/uploads/ALC-360%20Higgs3%202014-12-21.pdf)

#### Antenna PCB XX, Copper etched, Gold plated

- PCB material with Tg (Temperature, glassification) > 300 °C. (Details NOT TO BE disclosed)
- Copper etched antenna has much higher accuracy with lower tolerance than aluminum etched antenna and conductive ink printed antenna, which makes tag performance more consistent with lower read range variance.
- Gold is plated on chip bonded area of copper etched antenna, in order to enhance chip adhesion on antenna as well as electrical interconnection with antenna.

#### Packaging Single layer PCB, coated with high temperature resistant black ink

- Tag antenna has convoluted structure of two layers with copper ground plane on backside, connected through gold plated via-holes.
- Surface of PCBs is coated with XXXX (black) PSR, (made in Japan), best of kind which can protect it against electrical stress and water ingress.

#### Chip bonding Wire bonded, aluminum or gold

- Unlike other tag makers using flip chip bonding or chip soldering, Rfcamp has adopted wire bonding technology since year of 2004.
- Wire bonding, though most complicated and expensive chip bonding method, is most stable in electrical interconnection and most durable in mechanical and temperature stresses. It, with highest precision, is also best fit for working on complicated antenna patterns of double layer PCBs.

## [4] Secure HT Performance

- Performance table ([www.satcomresources.com/ERP-EIRP-Converter](http://www.satcomresources.com/ERP-EIRP-Converter))

Up to meters*	On metal	Off metal
2W ERP**	5.5	n.a.
2W EIRP***	3.0	n.a.

\* Measured at anechoic chamber, national lab. ([www.iot.nipa.kr](http://www.iot.nipa.kr)), South Korea

\*\* Measured by Alien Reader 9900+ ([www.alientechnology.com](http://www.alientechnology.com))

\*\*\* Measured by ATID Handheld AT880 ([www.atid1.com](http://www.atid1.com))

- Comparison with neighboring tags

	*dBm										
MHz	890	895	900	905	910	915	920	925	930	935	940
Secure HT	6.00	5.00	4.50	4.00	3.25	1.75 -	0.25 -	1.75 -	2.75 -	3.50 -	3.50
Secure	3.25	2.50	1.25	0.25 -	1.25 -	2.50 -	3.25 -	3.00 -	2.00 -	0.50	0.75

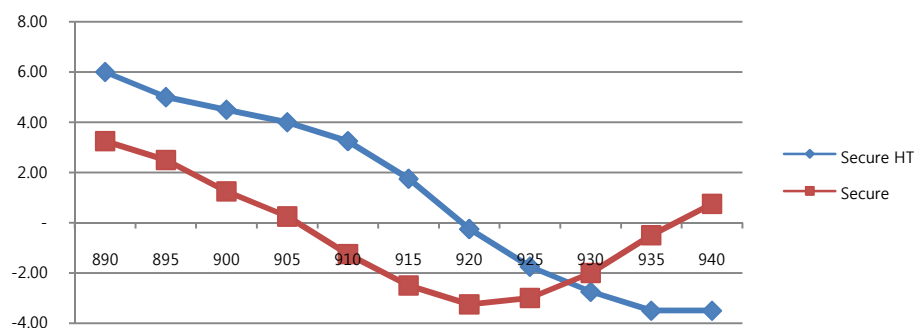

• **SECURE HT** reads up to 5.5 meters on metal, same as original SECURE. Though not best performing among similar size tags, its performance is most stable and consistent, as its slow and gentle slope of sensitivity curve shows.

• Its read performance varies upon tag location, orientation, direction, RF environments, etc.. Unlike other TITAN tags, its read performance is still same, even when space or backing adhesive between tag and metal surface gets thicker.

## • Comparison: on vs. off metal

- Comparison: with metal bolt in vs. without it in

	dBm										
MHz	890	895	900	905	910	915	920	925	930	935	940
w/o bolt	6.00	5.00	4.50	4.00	3.25	1.75 -	0.25 -	1.75 -	2.75 -	3.50 -	3.50
w/t bolt	5.75	4.75	4.25	3.75	3.00	1.50 -	0.50 -	1.75 -	3.00 -	3.50 -	3.50

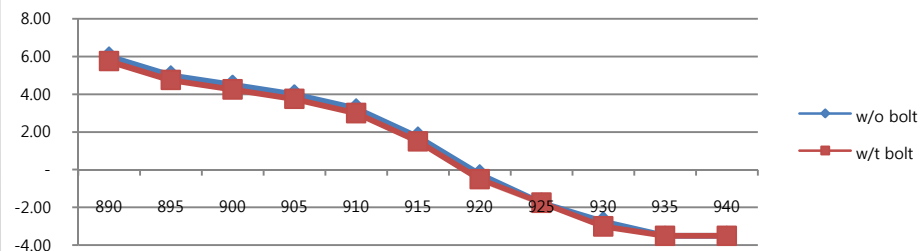

• **SECURE HT** reads same, regardless of whether it is fastened with metal bolt in two holes (located on center of both ends) or not. Stainless steel M3 bolt with round head is best fit for SECURE.

\*dBm : Minimum power tag needs in order to respond to RFID reader.

## [5] Secure HT Durability

### • Temperature stress

Test methods	Descriptions	Pass/Fail
230 °C, 5hrs	Stored in convection oven at 230C, 6hrs	Pass
20<>200 °C, 20 cycles	Stored in temperature shock chamber for 20 cycles – One cycle includes 1 hr. at 20C, 1 hr. transition, 1 hr. at 200C and 1 hr. transition.	Pass
85 °C/85%, 24hrs	Stored in humidity chamber at 85C/85%RH for 24 hours	Pass
Boiling water, 6 hrs	Immersed in boiling water for 6 hours	Pass

### • Ingression [www.dsmt.com/resources/ip-rating-chart](http://www.dsmt.com/resources/ip-rating-chart)

IP Class	IP68	1.5 meter deep immersion, 1hr

### • Mechanical stress

Test methods	Descriptions	Pass/Fail
Vibration	IEC60068-2-6/64	Pass
Drop& topple	IEC60068-2-31	Pass
Shock (acceleration)	IEC60068-2-22	Pass

### • Chemical stress

Chemicals	Descriptions	Pass/Fail
Alkali	NaOH (10%, pH13)   Immersed 24 hrs.	Pass
Acid	Sulfuric acid (10%, pH2)   Immersed 24 hrs.	Pass
Petroleum	Gasoline, Diesel, Kerosene, lubricating oil   Immersed 24 hrs.	Pass
Alcohol	Methanol, Ethanol   Immersed 24 hrs.	Pass
Surfactant	Solvent for metal tool oils   Immersed 24 hrs.	Pass
Salt water	IEC60068-2-11	Pass

### • Electrical stress

ESD	IEC61000-4-2 (LEVEL4 – 8KV)	PASS

### • Radiation stress (N/A)

Gamma ray	kGy	

ISO 11137-1:2012 Radiation/Gamma Ray method

### • Autoclave stress (N/A)

Autoclave conditions	Sterilization processes	

ISO 17665-1:2006 Moist Heat/Steam Sterilization method

## [6] Secure HT Options

### • Chip encoding service

- Encodes EPC memory sector only\*.
- Encodes tags with 4 multiple digits - from 16 bits (4 digits decimal or hex or ASCII) up to 480 bits (120 digits decimal or hex or ASCII) - upon customers' request.
- Unless requested by customer, all tags are encoded with 24 digits decimal (Date 8 digits + Serial 16 digits), before shipped to customers. For example, code 201508140000000000001278 tells that tag was 1278<sup>th</sup> encoded on August 14, 2015.
- Tag code can be permanently locked with password of 8 digits decimal or hex, upon customer's request.

\* For special encoding service (e.g. TID to EPC or user memory encoding), please ask RfCamp.

### • Label & printing service **NOT APPLICABLE**

- Provides fast and reasonably priced custom label service with printing variable data, barcode and logo.
- Label material is water proof and "hard to tear off" polysynthetic.



### • Laser engraving & direct printing service **NOT APPLICABLE**

- With CO2 laser, tag surface is precisely and permanently etched into variable data, barcode and logo with black and yellow contrast.
- With silk screen printing or pad printing method, tag surface is permanently printed with various colored logo or text.



### • Backing adhesive **NOT APPLICABLE**

- Unless requested otherwise, RfCamp recommends and applies 3M468MP or 3M9472LE (Aka. 3M300LSE) double-sided adhesive tapes for general applications. For harsh environments, RfCamp recommends 3M VHB tapes.
- For stronger adhesion, RfCamp suggests glue solutions such as Cemedine's Super X or Loctite's double compound epoxies.
- For special solution, please ask RfCamp.

### • Fasteners & brackets

- For some small TITANTAGs, metal fastener may adversely affect tag read performance, so please ask RfCamp for suitable solution.
- Upon customer's request, RfCamp develops metal based brackets for special applications, with optimal tag performance.



### • Encapsulations **NOT APPLICABLE**

- For special environment requiring enhanced chemical durability, RfCamp applies special coating materials over tag.
- Upon customer's request, RfCamp develops injection molded ruggedized case or rubber (polyurethane or silicone) based encapsulation.

